

Stellar® Service Crane

EC6000



EC6000★ TECHNICAL SPECIFICATION GUIDE



Our People. Our Products.



TECHNICAL SPECIFICATION GUIDE

■ SPECIFICATION INFORMATION

Crane Rating:	38,000 ft-lbs (5.25 ton-meters)
Standard Boom Length:	11' (3.35 m) from CL of Crane
Boom Extension:	
• 1st stage:	Hydraulic 60" (152.4 cm)
• 2nd stage:	Manual 60" (152.4 cm)
Max. Horizontal Reach:	21' (6.40 m) from CL of Crane
Maximum Vertical Lift: (from crane base)	22' 10" (6.96 m)
Boom Elevation:	-5 to +80 degree
Stowed Height: (crane only)	34.41" (87.40 cm)
Mounting Space Required:	20" x 21" (50.8 x 53.3 cm)
Shipping Weight:	1600 lbs (725 kg)
Controls:	Radio control standard for all functions
Winch	
• Rope Length:	90' (27.4 m)
• Rope Diameter:	5/16" (.79 cm)
• Line pull speed:	16 ft/min (4.88 m/min)
• Max. single part line:	3000 lbs (1360 Kg)
• Max. double part line:	6000 lbs (2720 Kg)
Rotation:	400 degree power (worm gear)
Lifting Capacities:	6000 lbs @ 6'4" (2720 Kg @ 1.9 m) 1810 lbs @ 21' (820 Kg @ 6.4 m)
Power Supply Required:	12 volt power unit 2.0 gpm @ 2900 psi (7.57 lpm @ 200 bars)
Min. Rec. Chassis (GVRW)	16,000

■ DEFINING CHARACTERISTICS

Planetary Drive Winch System

The winch is equipped with a 2.5 HP permanent magnet electric motor with a 199:1 planetary gear reduction system. This ensures that your winch will never quit lifting before it reaches the full rated capacity.

Double Boom Design

The double boom design makes it nearly twice as strong as the nearest competitor.

Gear Bearing Rotation

No plastic bushings or brass gears in the rotation system. It uses a high strength steel ball bearing turntable gear, a high strength steel worm gear, and a cast steel worm gear housing.

Integral Rotation Stop

400 degrees of rotation with an integrated rotation stop. Integrated stops allow the best performance while protecting wires and hoses from damage.

21' of Reach

Hydraulic 1st stage extension. Manual 2nd stage extension.

Radio Remote

Comes standard with a radio remote control.

Environmentally Friendly Hydraulic Oil

Stellar Industries uses environmentally friendly hydraulic oil in their EC Series of cranes, that is non-toxic, non-carcinogenic and that is recyclable and biodegradable.

NOTE: All Stellar® cranes meet ANSI B30.5 and OSHA 1910.180 specifications. Specifications subject to change without notification.

■ EC6000 CAPACITY CHART

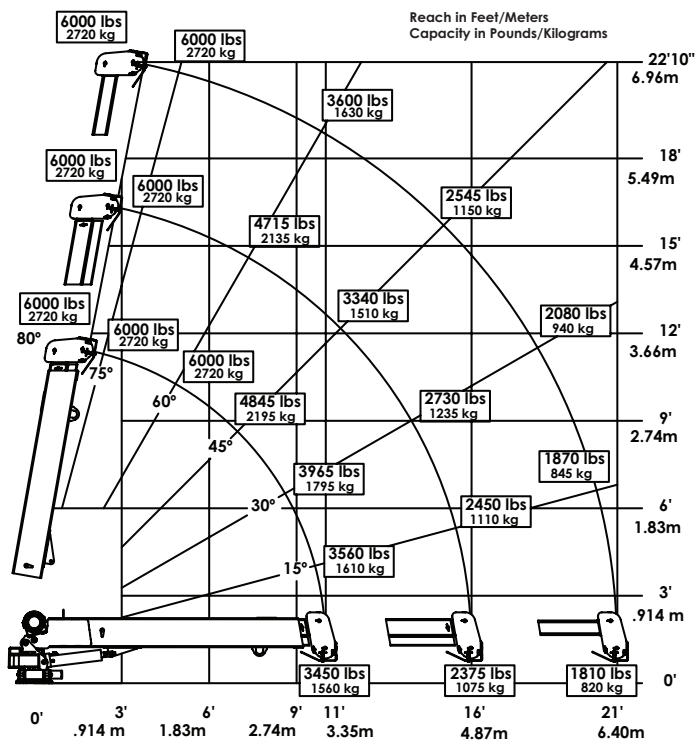

Weight of load handling devices are part of the load lifted and must be deducted from the capacity.

Maximum 1 - part line capacity is 3000 lbs. (1360 kg). For greater loads, use 2 - part line.

■ GEOMETRIC DIMENSIONS

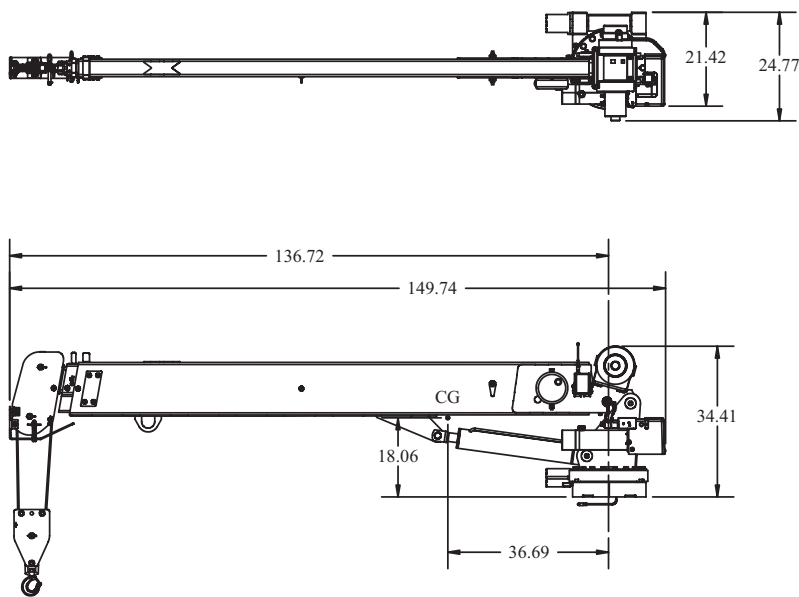

■ ROTATIONAL CLEARANCE

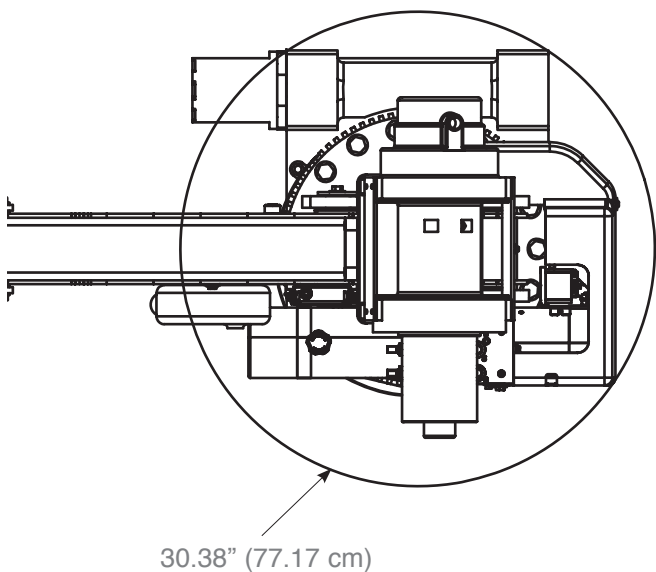

■ HOLE MOUNTING DETAIL

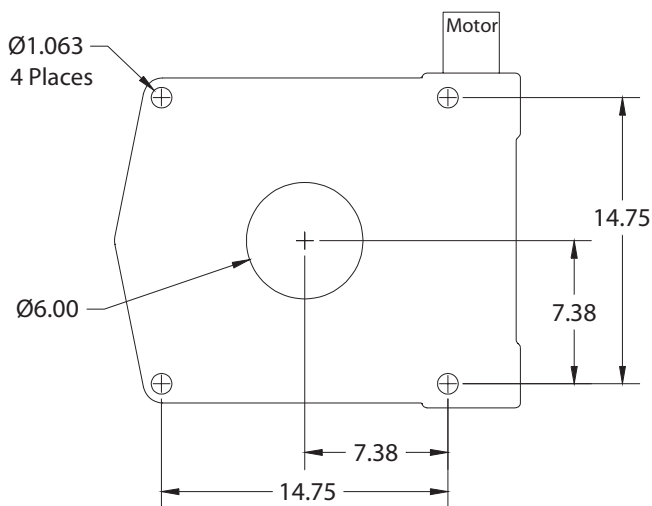

■ **SERVICE BODY MOUNT**

Mounts on 20" deep (or larger) side packs.

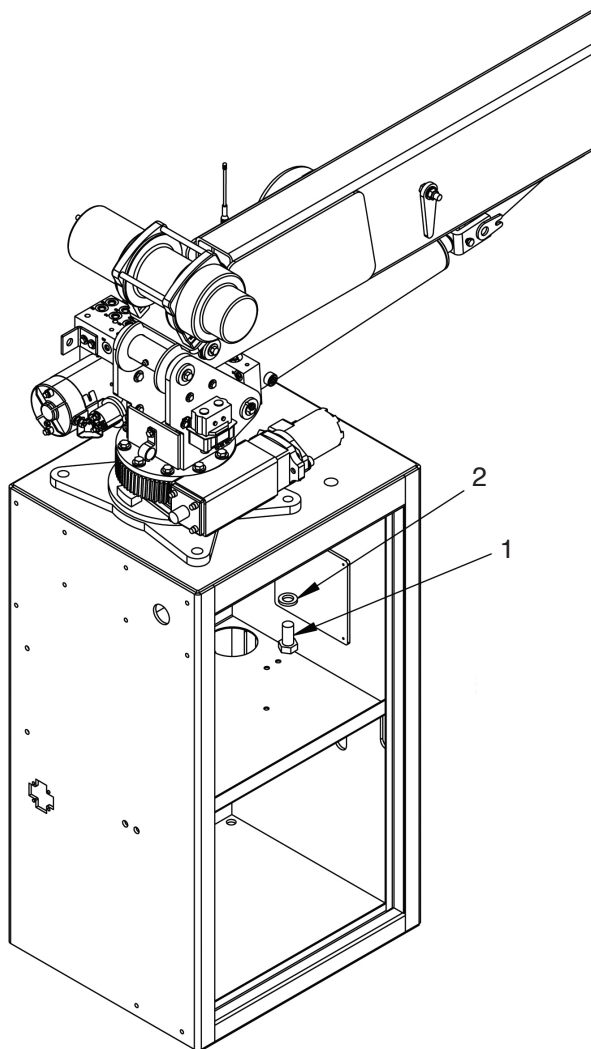

Item	Part	Description	Qty.
1	42985	Cap Scr 0.88-9x1.75 HHGR8ZY	4
2	8648	Washer 0.88 SAE GR8	4

Your local distributor:



Our People. Our Products.

190 State Street
P.O. Box 169
Garner, IA 50438
Telephone: (641) 923-3741 • (800) 321-3741
Fax: (641) 923-2812
Internet: www.stellarindustries.com
Email: sales@stellarindustries.com