

Stellar® Articulated Service Crane
6000MH



TECHNICAL SPECIFICATION GUIDE



Our People. Our Products.

STELLAR® 6000MH TECHNICAL SPECIFICATION GUIDE

■ SPECIFICATION INFORMATION

Crane Rating:	60,000 ft-lbs (8.30 ton-m)
Standard Boom Length:	14' 9" (4.50 m) from CL of Crane
Boom Extension:	
• 1st stage:	Hydraulic 70" (177.8 cm)
• 2nd stage:	Hydraulic 70" (177.8 cm)
Max. Horizontal Reach:	26' 5" (8.05 m) from CL of Crane
Maximum Vertical Lift: (from crane base)	29' (8.84 m)
Inner Lift Cylinder:	6" (15.24 cm) bore with integral pilot operated counterbalance valves.
Outer Lift Cylinder:	6" (15.24 cm) bore with integral pilot operated counterbalance valves.
Extension Cylinder:	2.5" x 2.5" (6.35 x 6.35 cm) bore piggy-back with pilot operated counterbalance valves.
Rotation:	450 degree power (worm gear drive)
Lifting Capacities:	6,000 lbs @ 10' (2720 kg @ 3.05 m) 4,050 lbs @ 14'9" (1837 kg @ 4.49 m) 2,275 lbs @ 26'4" (1032 kg @ 8.05 m)
Power Supply Required:	PTO and pump (8 gpm @ 3200 psi) (30.3 lpm @ 221 bars)
Controls:	Radio control standard for all functions.
Stowed Height:	7' (2.13 m)
Mounting Space Required:	30" x 30" (76.2 x 76.2 cm)
Approx Ship Weight:	4400 lbs (1995 kg)

■ DEFINING CHARACTERISTICS

Remote Control

Stellar Industries was the first U.S. manufacturer to include the state-of-the-art fully proportional multi-functional remote control as a standard feature. The radio remote incorporates a variable speed trigger that allows the operators to feather the crane with precise control. Additionally, the radio remote control handle features engine start/stop functions, compressor on/off, engine speed controls, and an emergency shut-off.

Hexagonal Boom Design

Hexagonal booms are stronger and greatly reduce boom flex and side to side movement.

Greaseless Bushings

Maintenance free greaseless bushings.

Stainless Steel Pivot Pins

Lower maintenance and extend life.

26' 5" of Hydraulic Reach

2-stage hydraulic extensions. No manual extensions.

Dual Acting Counter Balance Valves

Integrated into cylinders.

6620 CAPACITY CHART

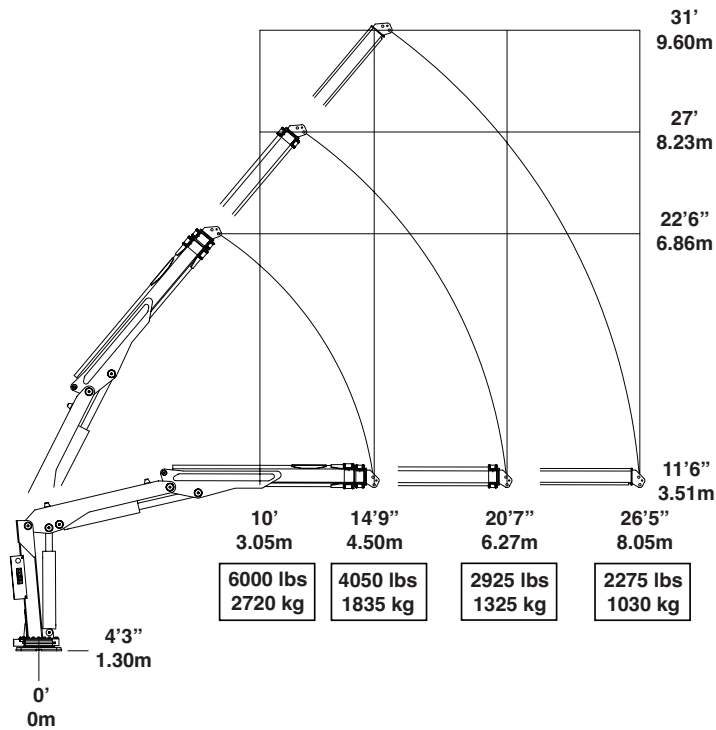

Weight of load handling devices are part of the load lifted and must be deducted from the capacity.

GEOMETRIC DIMENSIONS

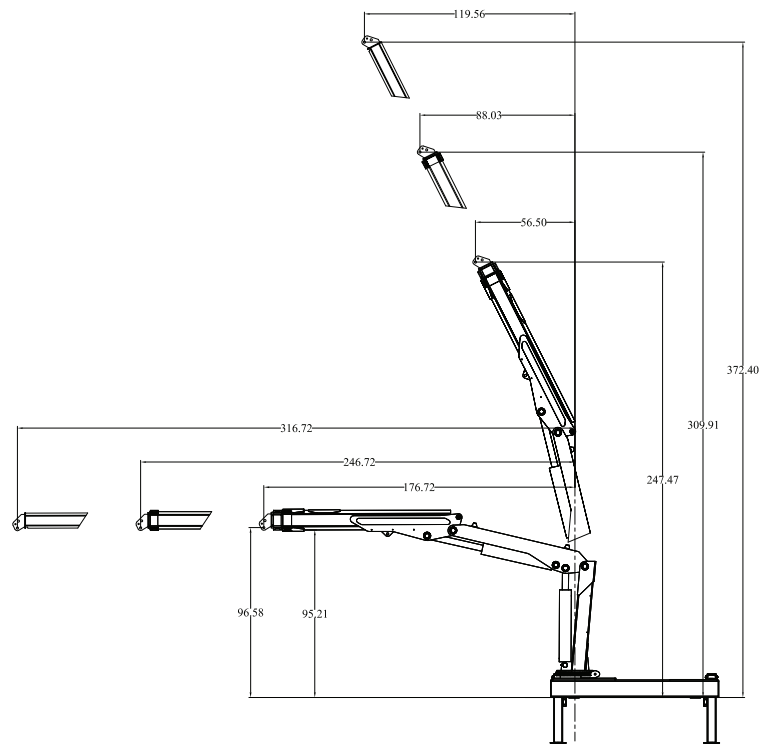

MOUNTING DETAIL

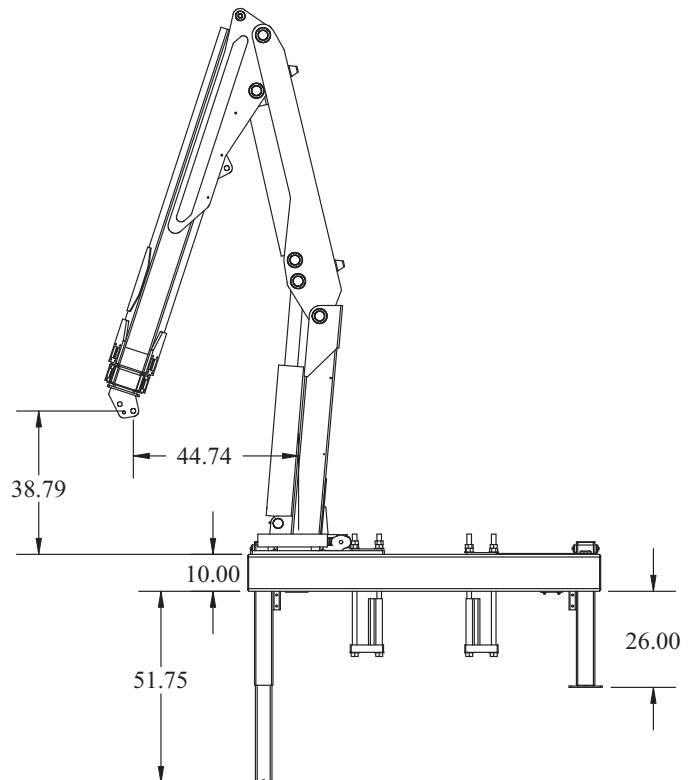
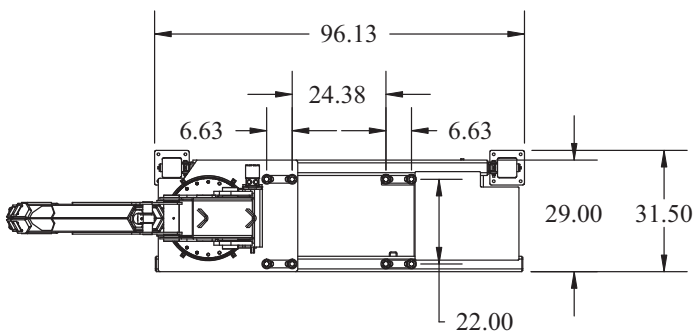

Stellar 6000MH Service Crane.

The Stellar Model 6000MH hydraulic articulating crane was created with the railroad industry in mind, but is applicable to many markets. The 6000MH has two 70" hydraulic extensions with a maximum horizontal reach of 26' 5" and a maximum vertical lift of 29' from the base of the crane. Rated at 60,000 foot/pounds, this machine is available with either a pedestal or truck frame-mounted base. Once again, Stellar offers trend-setting advantages available on this machine. In its class, the 6000MH is the leader in foot/pound rating with a 6,000 pound capacity at 10', and a full hydraulic extension out to a horizontal reach of 26' 5" from centerline of crane. Adding to this combination is standard heavy-duty hex boom construction and fully proportional radio remote control. Stellar Industries offers the crane of the future today for our discriminating buyers.



Your local dealer:



Our People. Our Products.

190 State Street
P.O. Box 169
Garner, IA 50438
Telephone: (641) 923-3741 • (800) 321-3741
Fax: (641) 923-2812
Internet: www.stellarindustries.com
Email: sales@stellarindustries.com

An Employee Owned Company.
Copyright © 2013 Stellar Industries, Inc.